

Charcoal Filters

N/A

Warranty

7 Years (Parts & Labour)

Lighting

1x 37w LED Panel 4000° Kelvin

Fuse Type

3 amp

EI Rating

A

Motor

1200m³/hr

Duct Size (6m Max Length)

150mm Minimum Round or Rectangular Equivalent

Remote Control

Yes

Metal Grease Filters

LA-60-Tolvi-SM x1 427x404

Switch Type

N/A

You must measure your mesh grill size. Older models will have different sizes to current models

Box Dimensions (CM) & Weight

LA-60-TOLVI-EXT 76x60x40 15Kg
External Motor 20Kg

**Extraction Rate
(Unrestricted)**

Speed 1
371m³/hr

Speed 2
588m³/hr

Speed 3
641m³/hr

Speed 4
1033m³/hr

Noise Levels DB/A

49 DB

56 DB

65DB

74DB



LUXAIR™
EXTRACTION WITH ATTRACTION

LA-60x60-Anzi External Motor

6" - 220 x 90 Ducting

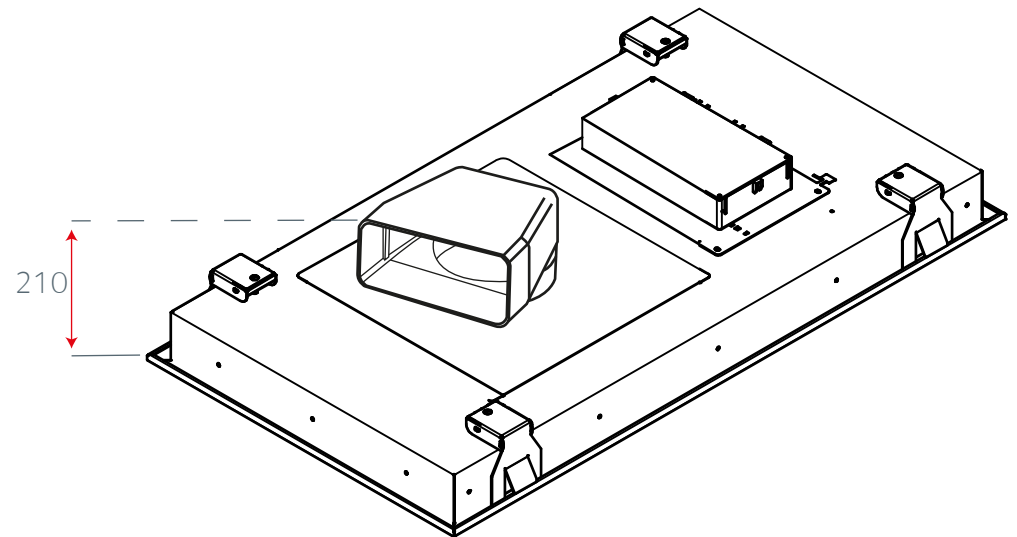
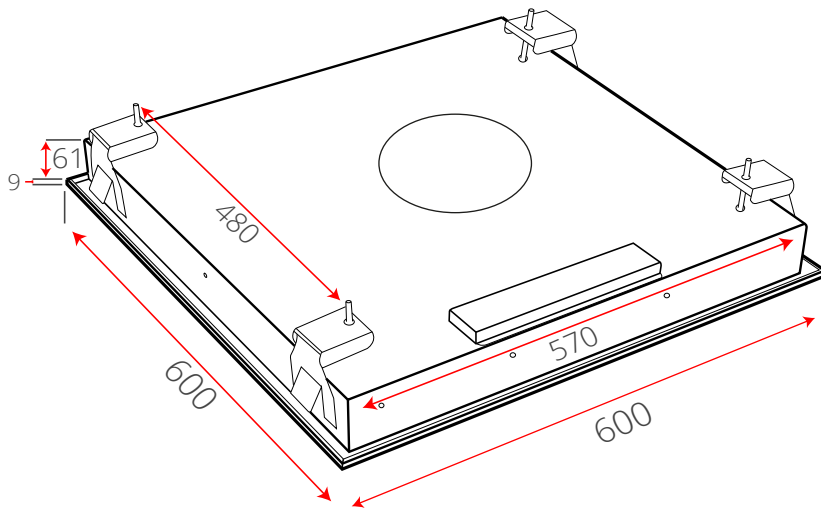
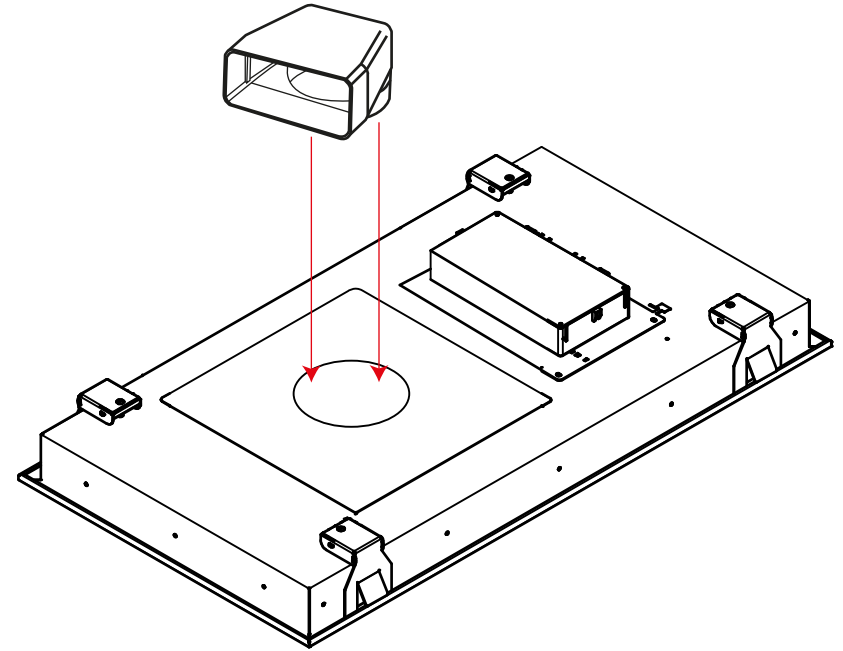
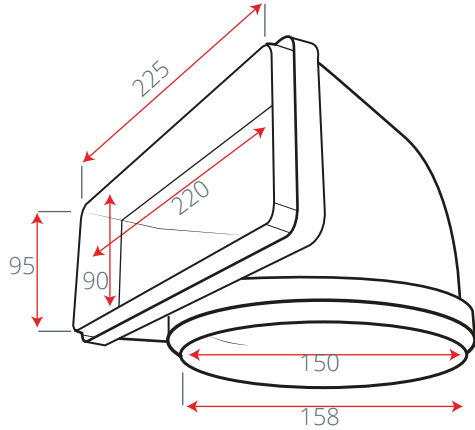

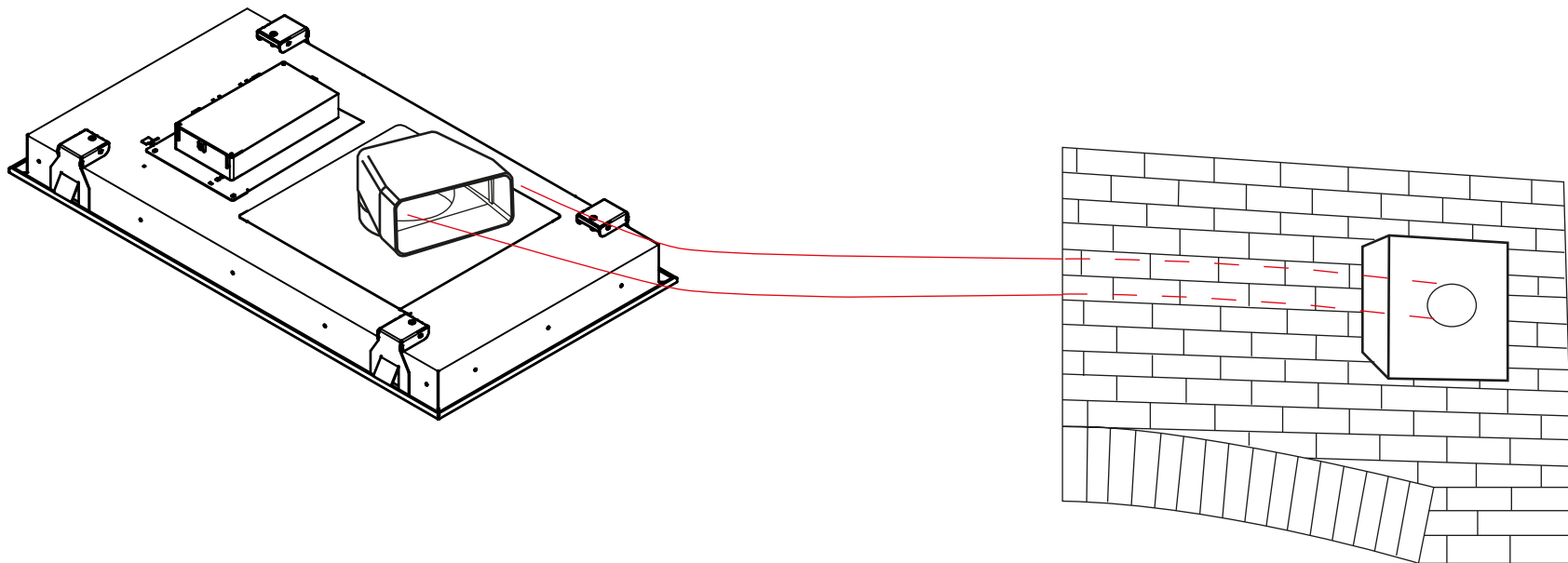

Wall Mounted External Motor

Pitched Roof External Motor

Flat Roof External Motor

