

Charcoal Filters

N/A

Lighting

6x LED Spot 1.2w 4000° Kelvin

EEl Rating

A

Duct Size (6m Max Length)

150mm Minimum Round or Rectangular Equivalent

Metal Grease Filters

LA-90-Anzi x3 350x200

You must measure your mesh grill size. Older models will have different sizes to current models

Warranty

7 Years (Parts & Labour)

Fuse Type

3 amp

Motor

1200m³/hr

Remote Control

Yes

Paint

White - RAL 9003 Glossy
Black - RAL 9004 Matt
SS - NA

Box Dims

76x60x38

Net Weight

17Kg

Gross Weight

23Kg

External Motor Net Weight

20Kg

**Extraction Rate
(Unrestricted)**

Speed 1
371m³/hr

Speed 2
588m³/hr

Speed 3
641m³/hr

Speed 4
1033m³/hr

Noise Levels DB/A

49 DB

56 DB

65DB

74DB



LUXAIR™
EXTRACTION WITH ATTRACTION

6" - 220 x 90 Ducting

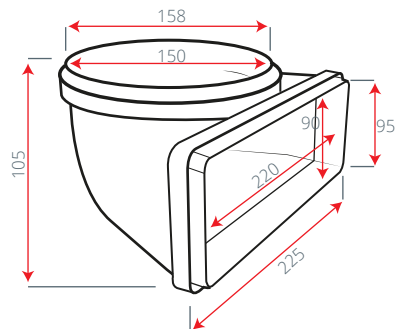

Please note adapters will not fit directly on to the motor exhaust. A small piece of round ducting pipe must be used first to connect any adapters

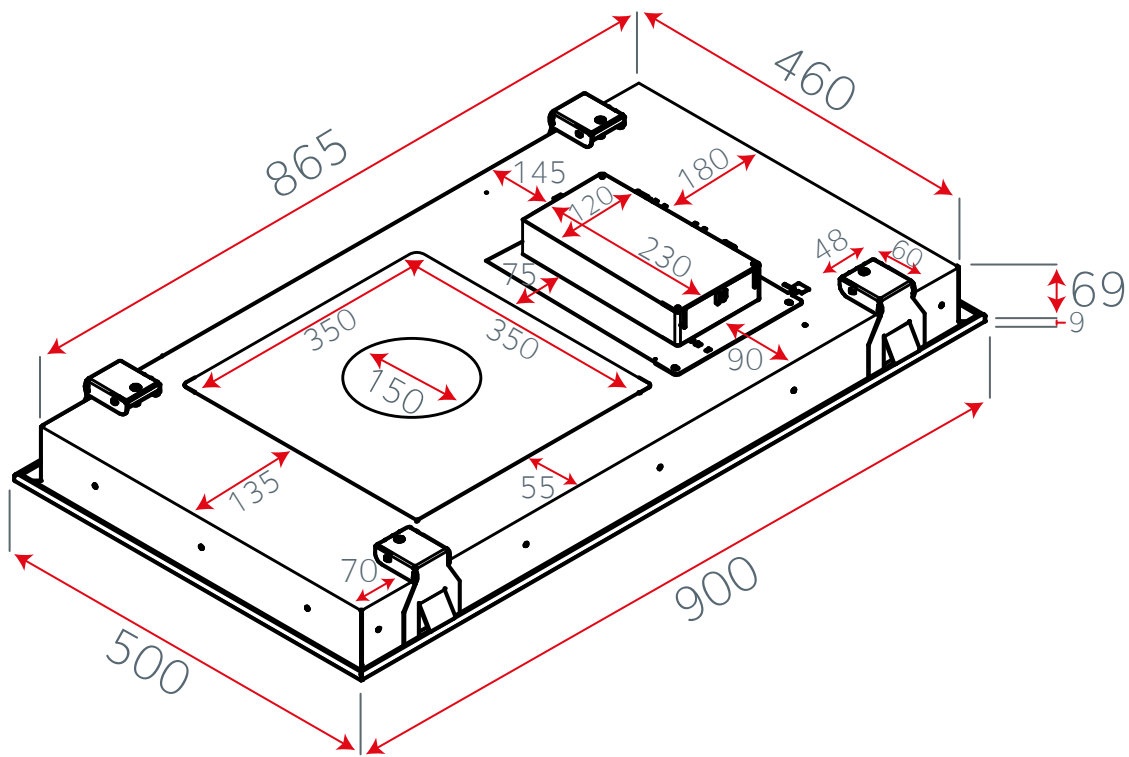
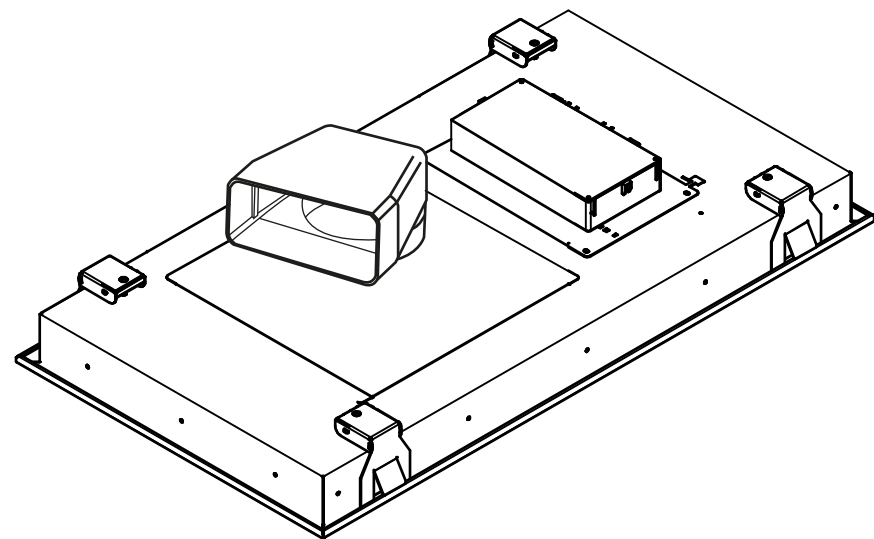
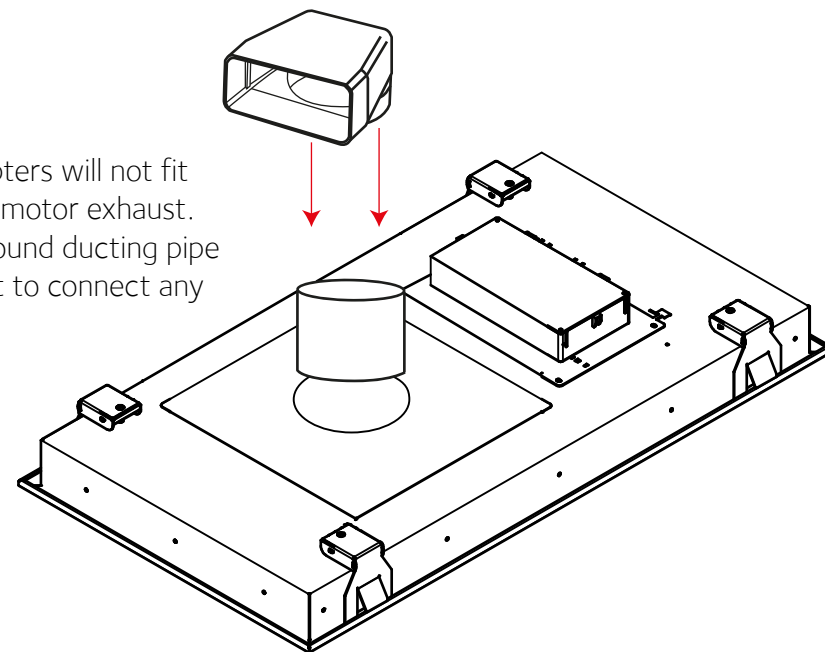

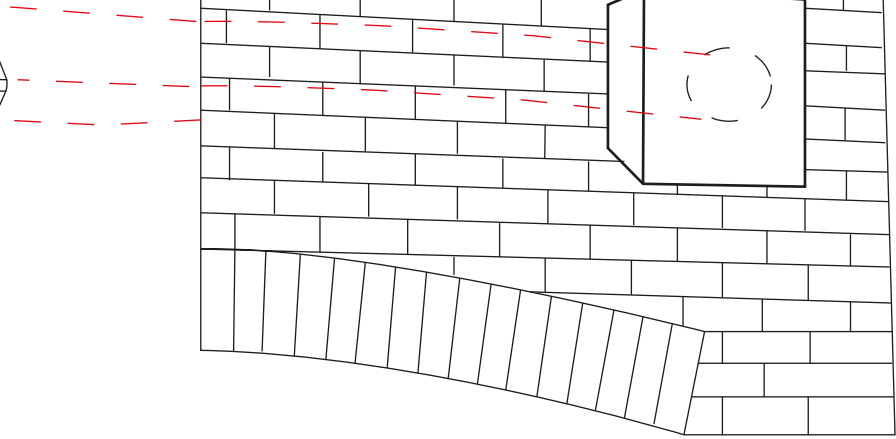
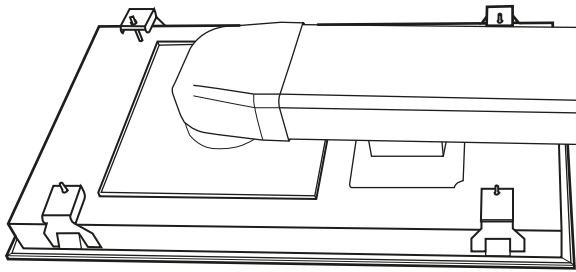

Wall Mounted External Motor

Pitched Roof External Motor

Flat Roof External Motor

